

# **THE MODEL 682A05 MACHINERY FAULT DETECTOR**

## **-A New Approach for Predicting Catastrophic Machine Failure**

by

James Robinson – *Emerson Process Management*

Mitchell Illig – *IMI Sensors*

Thomas Brown – *NSK Corporation*

Ray Limburg – *PCB Piezotronics*

### ***Abstract***

*Detecting mechanical faults in machinery has long been recognized as being important for preventing catastrophic failure and effective maintenance planning. The human senses of sound and touch were the first mechanisms used to detect machinery problems. Electronic sensors have since offered the ability to feel and listen to machinery with more precision, at more locations, and over more time than was ever before possible. Interpretation of the electronic signals delivered by these sensors has provided the maintenance engineer with the diagnostic information necessary to pinpoint machinery faults, thus enabling a more efficient and predictable maintenance effort. However, skilled and trained personnel have been required to effectively interpret this diagnostic information. As electronic sensors have become more sophisticated, so too have the diagnostic techniques, leading to the ability of earlier detection of failures with less required skill.*

*PeakVue data analysis offers a proven technique for the early detection of high frequency, impact-related failures, such as bearing or gear faults due to wear, loss of lubrication, and contamination. This method provides a measure of the true peak acceleration, at high frequencies, which gives an indication of impending failure. Trending PeakVue data can provide an indication of a problem that can be further diagnosed using spectral measurements. The acquisition and trending of PeakVue data has required the knowledge and use of expensive and sophisticated vibration data collection equipment, until now.*

*The Model 682A05 Machinery Fault Detector provides high frequency PeakVue data as a 4 to 20 mA output signal that can be monitored with conventional process monitoring equipment, such as a DCS, PLC, or SCADA system. Furthermore, the unit provides a second 4 to 20 mA output signal proportional to overall, low frequency vibration. This low frequency signal provides an indication of machine running speed faults such as imbalance, misalignment, and looseness. An analog output signal is provided for diagnostic, spectral measurements. The familiar DIN rail package installs conveniently alongside other process signal conditioners. The Model 682A05 Machinery Fault Detector uses proven, PeakVue early detection methodology, requires less operator training, works with existing process monitoring equipment, and offers the advantage of 24/7 monitoring.*

## 1. Introduction

IMI Sensors<sup>1</sup> (A Division of PCB Piezotronics, Inc.) Model 682A05 Machinery Fault Detector module is a DIN rail signal conditioner that interfaces to an ICP<sup>®</sup> accelerometer. The device converts the accelerometer signal into two industry standard 4-20mA output signals. The first 4-20 mA output is linearly representative of the overall vibration level in velocity or acceleration units. This overall velocity vibration level is acquired over a 10-1000 Hz bandwidth, which is sensitive to machine faults such as imbalance, misalignment, and others that manifest themselves at lower frequencies around running speed or harmonics thereof.

The second 4-20 mA output is representative of the high frequency (>1000 hz) peak g-level. Many machinery problems are accompanied by short duration energy faults (generally categorized as stress waves), which are detectable by an accelerometer located in the proximity of the fault. Stress wave activity accompanies faults such as impacting, fatiguing, and friction, which occur at frequencies above 1000Hz. Experience has shown the amplitude (as measured with an accelerometer) of the stress waves provide a reliable indicator of the severity of the fault. The reliability is further enhanced with continuous monitoring of the stress waves for which the model 682A05 is designed to accomplish.

The model 682A05 observes these stress waves over a time period sufficient to incorporate a minimum of 6 revolutions of the machine being monitored. A logarithmic scale is used for the peak g-level to accommodate a dynamic range sufficient to the g-level change from a smooth running machine to a machine with serious faults.

This paper discusses case studies establishing the correlation of the peak g-levels with fault detection and severity assessment based on the peak value (PeakVue<sup>™</sup>) analysis methodology introduced by Emerson Process Management<sup>2</sup>, CSI in 1997. The 682A05 is then presented with controlled test results and compared to data obtained with PeakVue<sup>™</sup>.

## 2. Background

The methodology employed in the Model 682A05 Machinery Fault Detector is based on experience gained from PeakVue applications. With PeakVue, spectral data is employed to identify the specific component faults and the time waveform is used to detect faults and assist in the assessment of the severity of the faults. A brief description of the PeakVue methodology follows:

1. Select analysis bandwidth sufficient to include the anticipated maximum fault frequency with a few harmonics.
2. Select a high pass filter greater or equal to the maximum frequency selected in the previous step. The signal being analyzed is passed through this filter.
3. Select the number of lines to be employed in spectral analysis to ensure the capture of data over 15 or more revolutions of the machine being analyzed.
4. The PeakVue time block of data consists of absolute peak values from the time waveform observed over each time increment within the data block
5. When the PeakVue time block of data is filled, a spectral analysis on the time waveform can be performed. The peak g-level within the time block is saved for trending and fault severity assessment.

From each PeakVue analysis time block, a single peak value is obtained for trending. That peak value is the maximum absolute g-level observed over several revolutions (15+ recommended) of the machine being monitored and is the foundation of the 682A05 methodology.

Results demonstrating the correlation of the peak g-level from PeakVue to fault presence and severity for three cases are presented. The first is for an accelerometer mounted on the input shaft bearing housing of a large roller mill gearbox turning at 893 RPM. The second is for an accelerometer mounted on the bearing housing over the output shaft of a pinion stand gearbox turning at 150 RPM. The third case presents the correlation of the peak g-level to a lubrication fault in a large machine turning at 10 RPM.

### Case # 1: Roller Mill Gearbox

The PeakVue time waveform for 15 revolutions of the input shaft on the roller mill gearbox is presented in Figure 1. The analysis bandwidth was set at 400 Hz and the time increments for each data point in the PeakVue time waveform is 0.977 msec. The number of data points in the PeakVue time waveform is 1024.

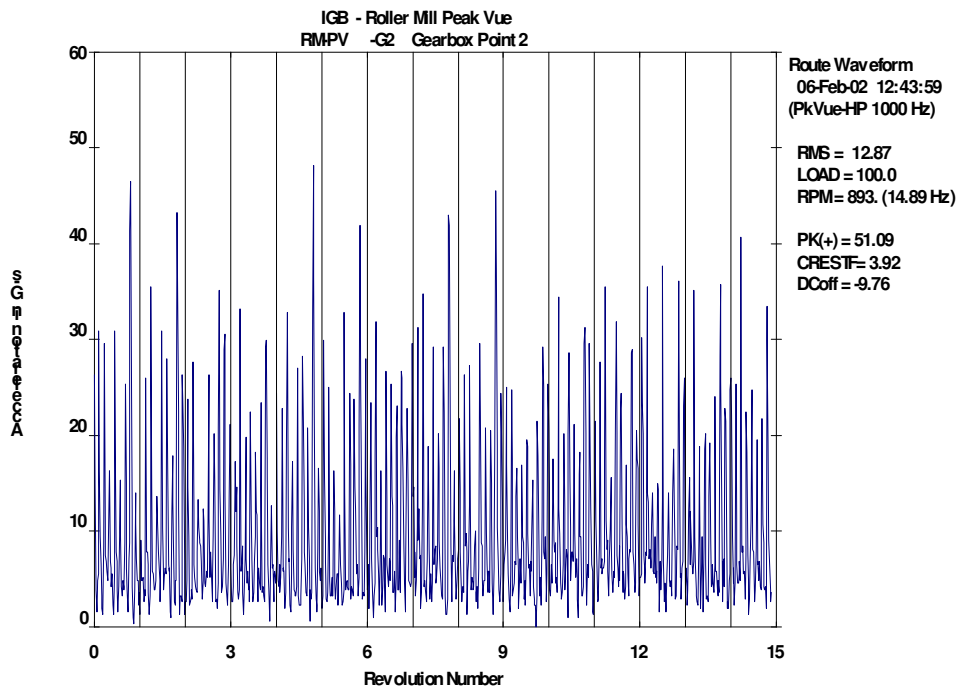

**Figure 1**  
PeakVue time waveform on input shaft to roller mill gearbox at 890 RPM

Each of the 1024 data points in the PeakVue time data block contains the absolute peak value that was detected over each sequential 0.977 msec time increment. For the entire time data block (which includes 15 revs of the shaft) the peak value is 51g's, which is the parameter recommended for trending when carrying out PeakVue analysis.

The trended values for this measurement point (input on roller mill gearbox) over a 300 day time period are presented in Figure 2. Note that the alert and alarm levels are those recommended for the machine fault detector as described later in this paper.

Peak g Trend Data For Measurement Point G2

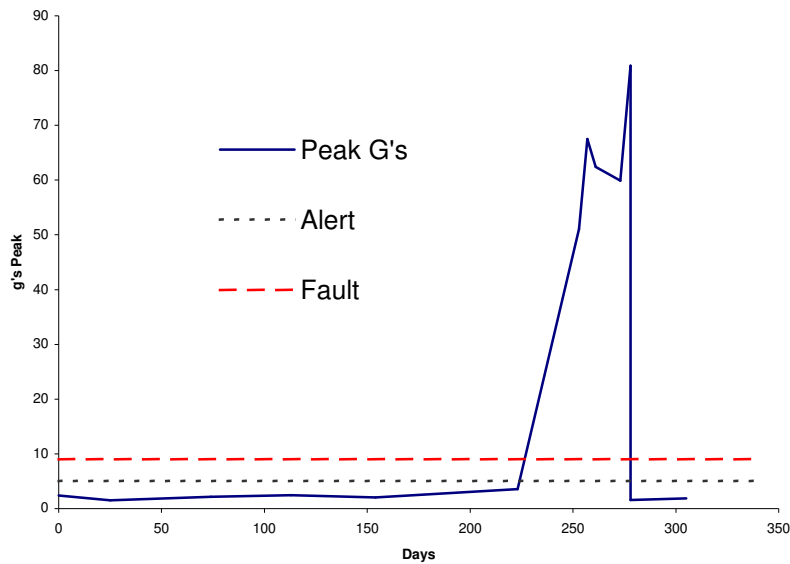

Figure 2

Trended peak g-level from input shaft to roller mill gearbox at 890 RPM

The PeakVue spectral data (computed from the PeakVue time data presented in Figure 1) positively identified the fault as an inner race fault. Based on the peak g-levels, a decision was made to replace the bearing around day 275 in Figure 2 (g-levels around 80 g's). The peak g-level returned well below the alert level (see Figure 2) post bearing replacement. A picture of the removed bearing showing the inner race fault is presented in Figure 3.

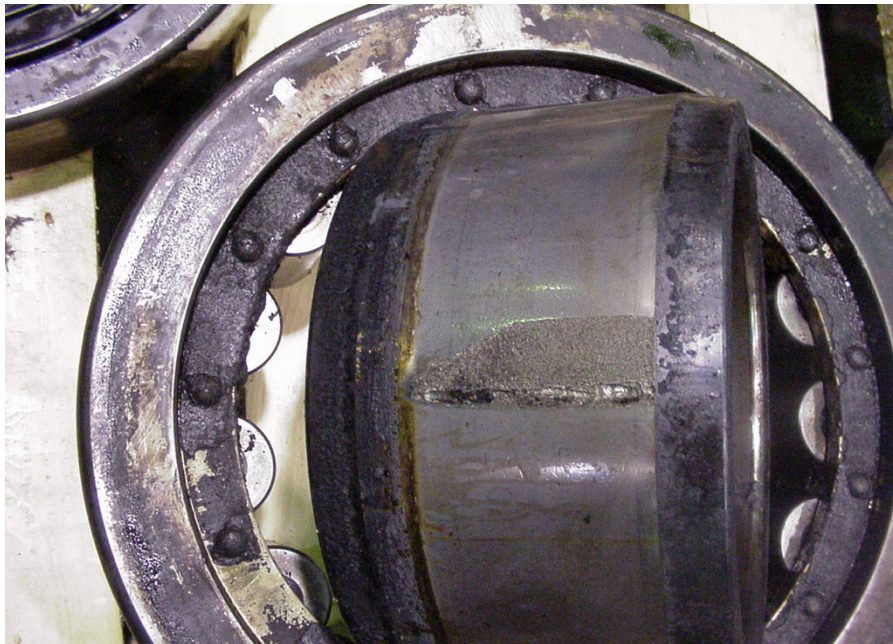
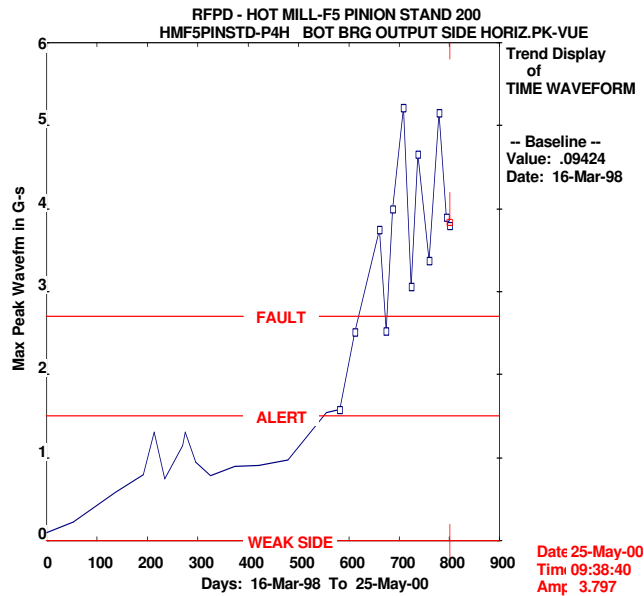

Figure 3

Damaged bearing from Roller Mill Gearbox

## Case # 2: Pinion Stand Gearbox

The trended peak g-level over an 800 day time period from a measurement point on the bearing housing of the output shaft (turning at 150 RPM) of a pinion stand gearbox is presented in Figure 4. The alert/alarm levels shown on Figure 4 are extracted from the recommended baselines for the Machine Fault Detector. The trended parameter exceeded the alert level on September 23, 1999, and was replaced following the last data point (May 25, 2000) in Figure 4.



**Figure 4**

Trended peak g-level from output shaft at 150 RPM of pinion stand gearbox.

A picture of the defective bearing is presented in Figure 5. Clearly this bearing was near catastrophic failure. Following bearing replacement, the peak g-level returned to levels experienced in July/August 1998.

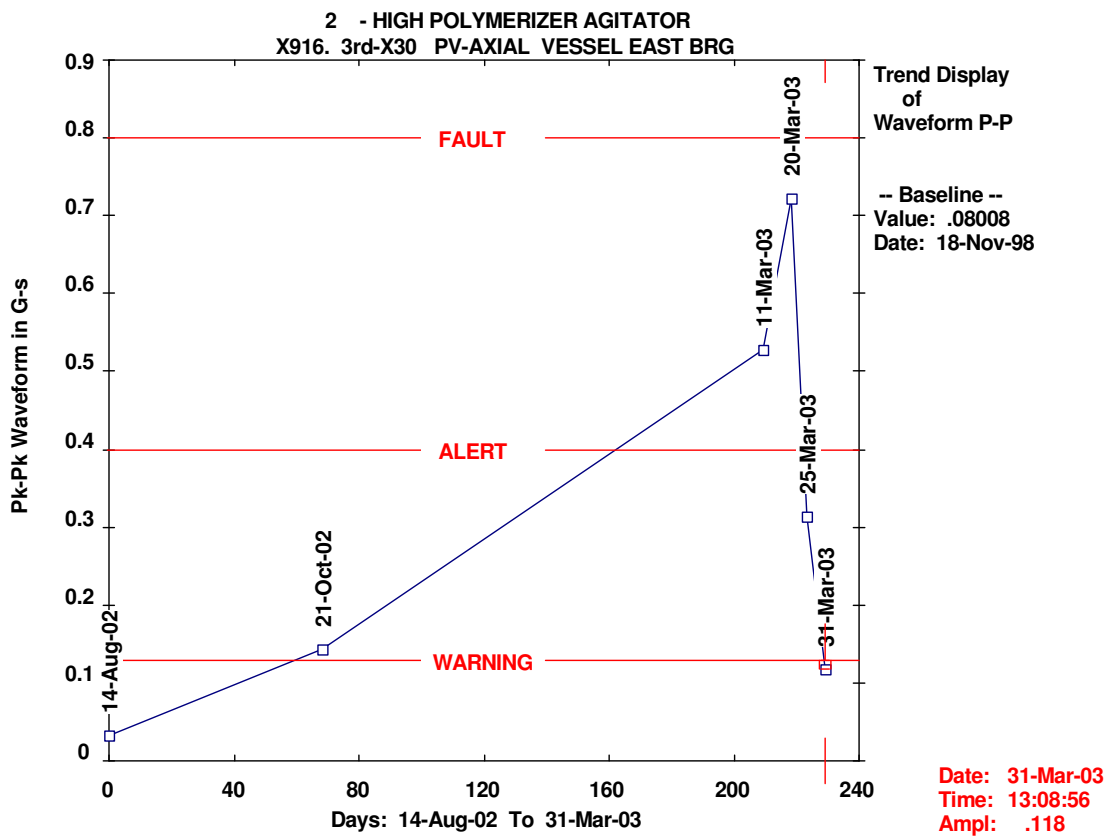

**Figure 5**

Defective Inner Race from output shaft turning at 150 RPM of pinion stand gearbox.

### Case # 3: Large Slow Speed Machine

The third case is for a large machine turning around 10 RPM where fault in this case is a lack of lubrication. Referring to Table 1 (next section), the recommended alert and alarm levels are 0.1 and 0.18 g's respectively for this speed machine. The trended peak g-level from this machine is presented in Figure 6. The peak g-level obtained on October 21, 2002 (0.14g's) is greater than the recommended alert level. Following the reading acquired on October 21, 2002, the machine was shutdown and taken through major overhaul. The machine was started up again around March 11, 2003 and the peak g-level was measured to be 0.52g's (well above the alarm level of 0.18g's). A second (post rebuild) reading was acquired on March 20, 2003 yielding a peak g-level of 0.73g's. On March 25, 2003, a small amount of grease was added to the bearing resulting in an immediate decrease in the g-level reading to 0.32g's. A postulate was then advanced that the bearing was cleaned out during rebuild but was not repacked. Sufficient grease was then added to pack the bearing with a resultant decrease in the peak g-level to the pre-rebuild g-level of around 0.12g's.



**Figure 6**  
Trended peak g-level from polymerizer agitator at 10 RPM

### 3. Model 682A05 Machinery Fault Detector Methodology

The two primary outputs from IMI Sensor's Machinery Fault Detector (682A05) are:

1. 4-20 mA linearly proportional to the RMS/peak overall of the input from the accelerometer in either g or ips units.
2. 4-20 mA proportional (on a log scale) to the absolute peak g-level of the high frequency (greater than 1 KHz) component of the input from the accelerometer in g-units.

As shown in Flow Diagram 1, the RMS/peak overall value is obtained with a True RMS/DC converter. The output of the RMS/DC converter is the input to a V/I converter providing the 4-20 mA output signal (proportional to the RMS/peak overall). The input to the RMS/DC converter is either the output of the accelerometer (if g-units are being used) or the output of an analog integrator scaled to convert g's to ips units (if ips units are being used). The user selects the full scale reading through dipswitch selections within the Machinery Fault Detector Module.

For the peak g-level output, the signal from the accelerometer is routed through a high pass filter set at either 1 KHz or 5 KHz (dip switch selectable). The output from the high pass filter is 1) full wave rectified, 2) routed through a log amplifier, and 3) routed to a peak follower circuit which captures the peak value over a preset time interval (factory setting with default interval of seven seconds). At the conclusion of each present time interval, the peak hold signal is accepted as the module output for the next time increment. The peak hold circuit is rapidly zeroed out, and continues gathering peak values over the next time increment (the output lags the input by one time increment). The requirement on the time increment must include a minimum of six revolutions (15 is desirable) of the machine being monitored. Therefore, the factory set "7 second" increment is useable for machinery turning as low as 50 RPM.

Experience with PeakVue has demonstrated that it is not unusual to experience g-levels of 50+ g's with some faults and at the same time, that same signal can be less than 0.2 g's in the absence of faults. Therefore it is desirable to accommodate a 60+dB dynamic range in the output. Thus, the accelerometer signal is routed through a log amplifier followed by a peak hold module (hold time set by factory). The V/I module providing the 4-20 mA output follows the peak hold module. A typical Fault Detector output of g's versus mA is presented in Figure 7, which demonstrates that a linear relationship exists over a 60 dB dynamic range.

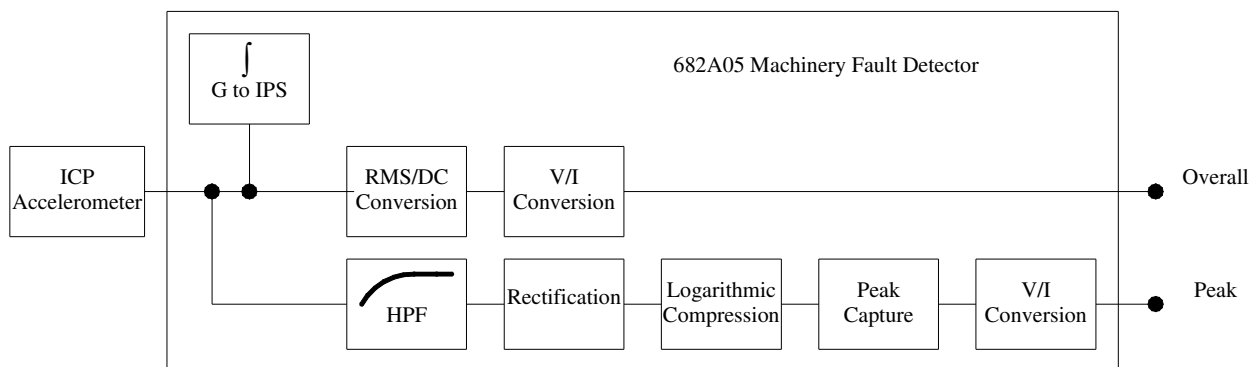

Flow Diagram 1

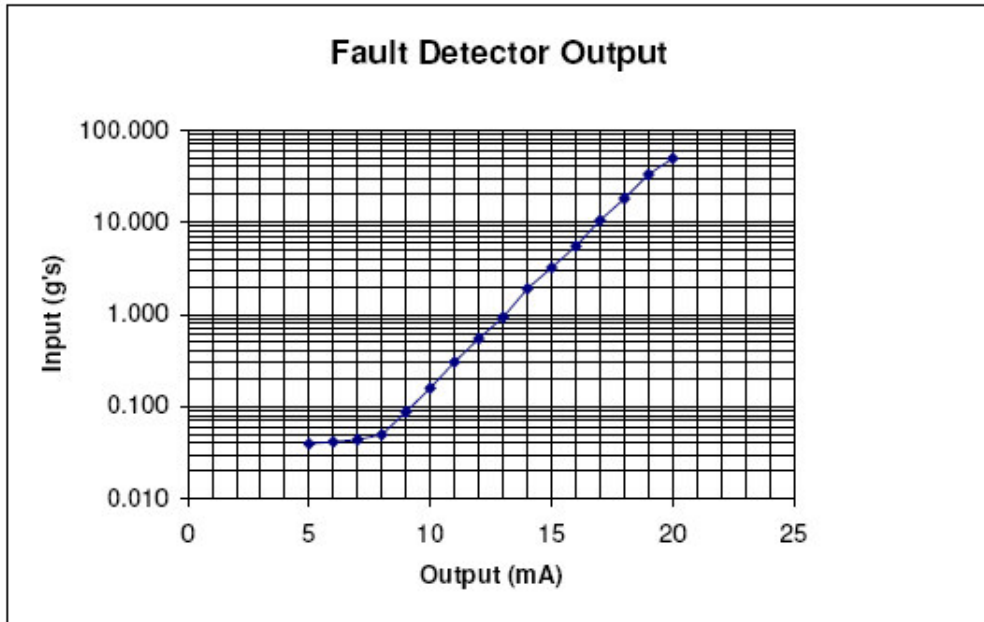

**Figure 7**

Translation curve for 4-20 mA output of Machinery Fault Detector to input g- level

The peak g-level (observed over 6+ revolutions) is the parameter used to identify the presence of fault and establish the severity of the fault. The output of the Machinery Fault Detector provides the ability to monitor/trend the peak g-level on a 24/7 basis. When a fault appears and progressively increases in severity, the peak g-level will correspondingly trend upward. Experience from PeakVue enables the ability to establish generic alert and alarm levels (based on the speed of the machine), which can be used as guidelines. The recommended generic alert and alarm levels are presented in Table 1. The generic levels can be “reset” for each individual measurement point once baselines are established.

<b>Speed Range (RPM)</b>	<b>Alert Limit (Peak g-level)</b>	<b>Alarm Limit (peak g-level)</b>
less than 5	0.100	0.180
5 - 10	0.150	0.270
10 -20	0.200	0.360
20 - 60	0.400	0.720
60 - 150	1.000	1.800
150 - 400	2.000	3.600
400 - 700	4.000	7.200
700 - 4000	5.000	9.000
4000 - 10000	7.000	12.600

**Table 1**

Recommended Alert and Alarm Levels (Generic)

## 4. Test Results

Several tests under controlled conditions have been carried out to establish that the peak g-level from the Machinery Fault Detector is approximately the same obtained using PeakVue and that the peak g-level exhibits a significant upward trend as the severity level increases. To establish similarity in the peak g-level from the Machinery Fault Detector to that obtained from PeakVue, the test conducted was simply to obtain data from both devices on several bearings. To establish an upward trend with severity level, bearing faults were purposely introduced. The faulty bearings were then run under a 50% dynamic load (about five times typical loads) until catastrophic failure is observed.

The peak g-level readings obtained from the Machinery Fault Detector module and from the PeakVue methodology at approximately the same time for several test cases are presented in Table 2. Clearly the two methodologies are in agreement relative to the peak g-level results.

### **PEAK G-LEVEL (G'S)**

<b><i>Machine Speed (RPM)</i></b>	<b><i>Machinery Fault Detector</i></b>	<b><i>PeakVue</i></b>
1000	1.6	1.7
2000	4.8	4.6
1000	1.6	1.8
2000	4.8	4.8
1800	1.0	1.0
1800	4.5	4.2

**Table 2**

Comparison between PeakVue and MFD

At the NSK Bearing Test Facilities<sup>3</sup>, faults were introduced into specific bearing components by an inscription pin. The bearings were then loaded at 50% dynamic load (about 5 times that experienced normally) and run until catastrophic failure occurred. Catastrophic failure was determined by one of the following:

- 1) Shaft Lockup
- 2) Temperature exceeds preset level
- 3) A trip point set from shock level (SPM technology) was exceeded.

The output of the Machine Fault detector module was recorded over the test period. Some tests ran approximately 7 days prior to failure while others failed in approximately 7 hours (no consistent pattern was observed).

There were 10 separate bearing tests carried out. A defect was formed on six of the ten bearings (two each on the ball, outer race, and inner race) with an electric discharge-marking pin. No defects were introduced on one bearing. Two bearings were under lubricated and one over lubricated. Each of the bearings were operated at 50% of dynamic load rating (about 5 times the normal load) and ran either until failure occurred or terminated because of elapsed time. Running speed for all bearings was 1800 RPM.

The alert and alarm levels for bearings running at 1800 RPM would be set at 5 g's and 9 g's respectively (see Table 1). However, these test bearings were running under extreme loads and hence are not expected to fall under the same alarm/alert levels. Selected graphical results are presented below.

The results from one of the two defective bearings are presented in Figure 8. The duration of the test was approximately 3.2 days with the final excursion lasting about 15 hours. Note how the g-levels were rapidly increasing at the end of the test (terminated by either temperature or high shock levels).

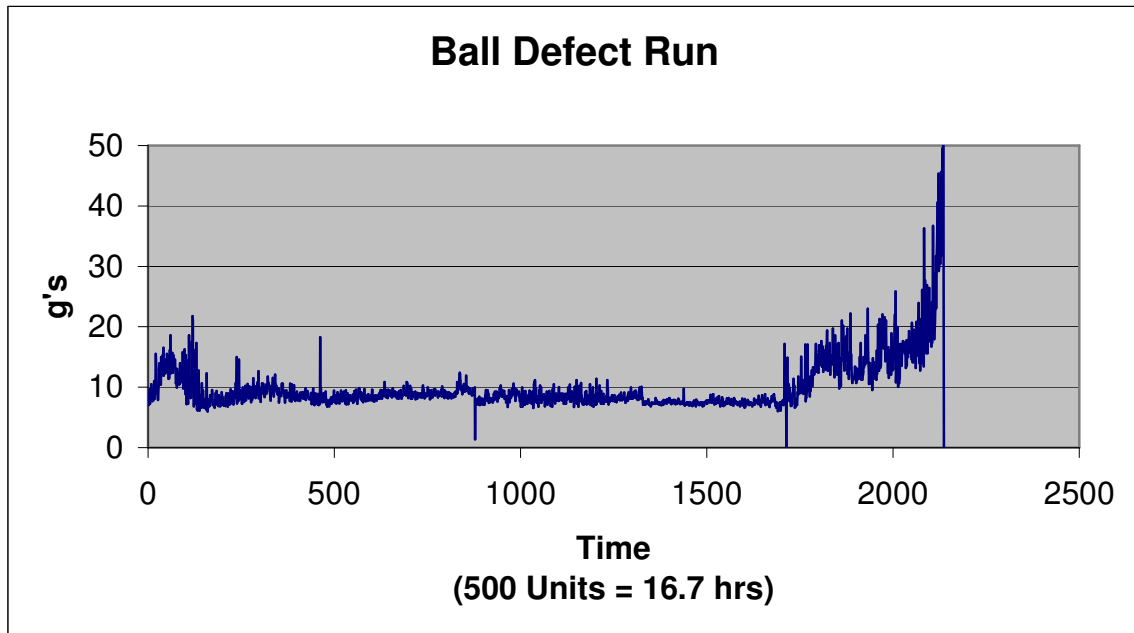

**Figure 8**

Output from a defective ball test run at NSK under 50% dynamic load until termination.

A graphical result from one of the two bearings with an inner race fault is presented in Figure 9. The duration of the test was about 31.5 hours. The excursion at the end of the test lasted about 1.5 hours. If an alarm/alert had been set, it would not have been exceeded until the final excursion.

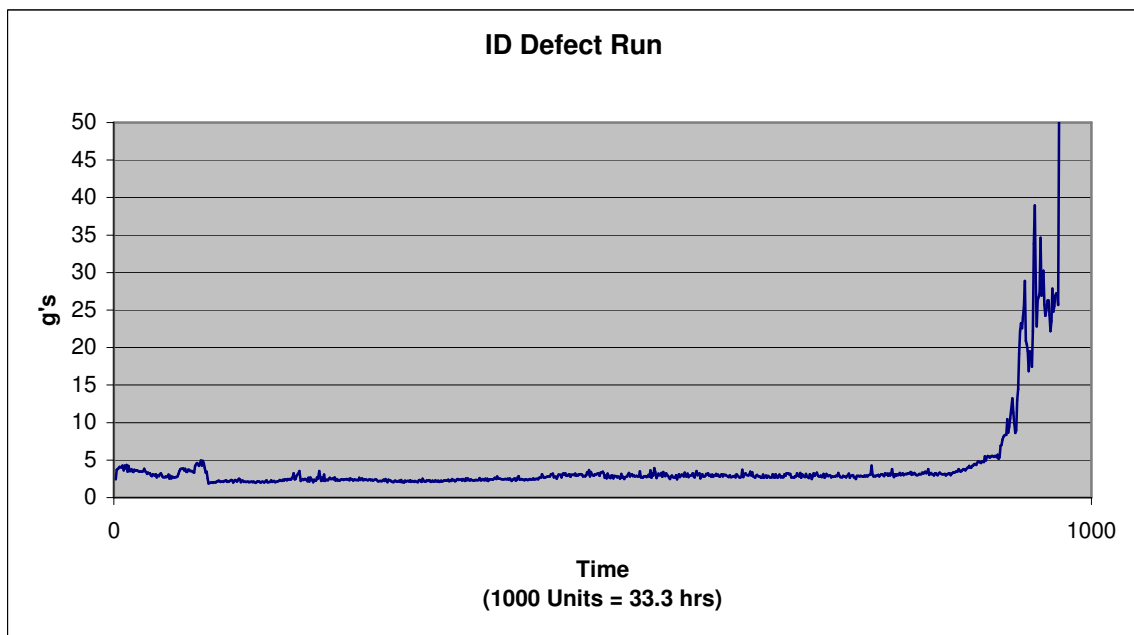

**Figure 9**

Output from a defective inner race test run at NSK under 50% dynamic load until failure.

Graphical data (g's versus time) from one of the two under lubricated test bearings is presented in Figure 10. The duration of the test was about 6.5 days (terminated because of time). A probable alarm/alert level was exceeded about 40 hours into the test. There were excursions above a probable alarm level throughout the test accompanied by an upward trend in the baseline, but there was not an indication that the bearing was near catastrophic failure.

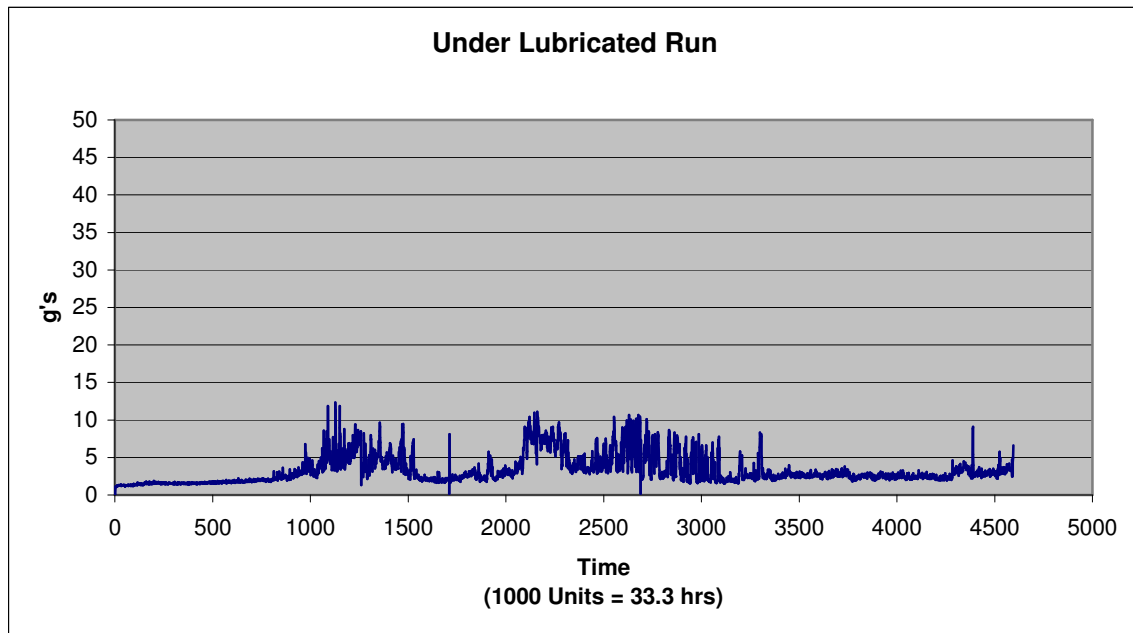

**Figure 10**

Output from an under lubricated bearing test run at NSK under 50% dynamic load until terminated (no failure).

## 5. Conclusion

The Model 682A05 Machinery Fault Detector provides an output, which is representative of the peak g-level experienced by an accelerometer for the high frequency (frequencies greater than the factory set high pass filter) components of the signal. The g-level from the machinery fault detector module was demonstrated to be essentially the same as that obtained from the PeakVue methodology.

The peak g-level has proven, through long-term experiences with PeakVue, to be both a reliable detector of the presence of a fault and a reliable indicator of the severity of the fault. Since the output of the machinery fault detector is essentially the same as the peak g-level from PeakVue, it follows that the output of machinery fault detector will yield data for reliable fault detection and provide assistance in establishing the severity of the fault.

Tests were carried out at an NSK Corporation bearing test facility where intentional faults were introduced into bearings run under 50% rated dynamic load until either catastrophic failure occurred or allotted time for the test expired. In every case where catastrophic failure occurred, there were significant increases in the peak g-level (output of the machinery fault detector) over a time period preceding the failure.

<sup>1</sup> *IMI Sensors*  
3425 Walden Avenue  
Depew, NY 14043 USA

<sup>2</sup> *Emerson Process Management, CSI*  
835 Innovation Drive  
Knoxville, TN 37932 USA

<sup>3</sup> *NSK Corporation*  
4200 Goss Road  
Ann Arbor, MI 48105 USA